

Lesser Open Bee
License 1-3



Bee-Plane™ Project description for TRL2



Project origin

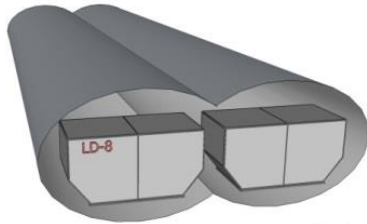

Bee-Plane ©

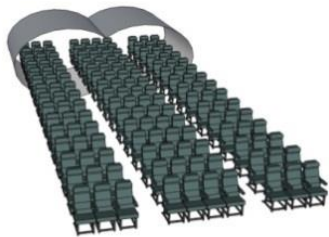

Bee-Plane ©



Copyrights Wikipedia MM Karim

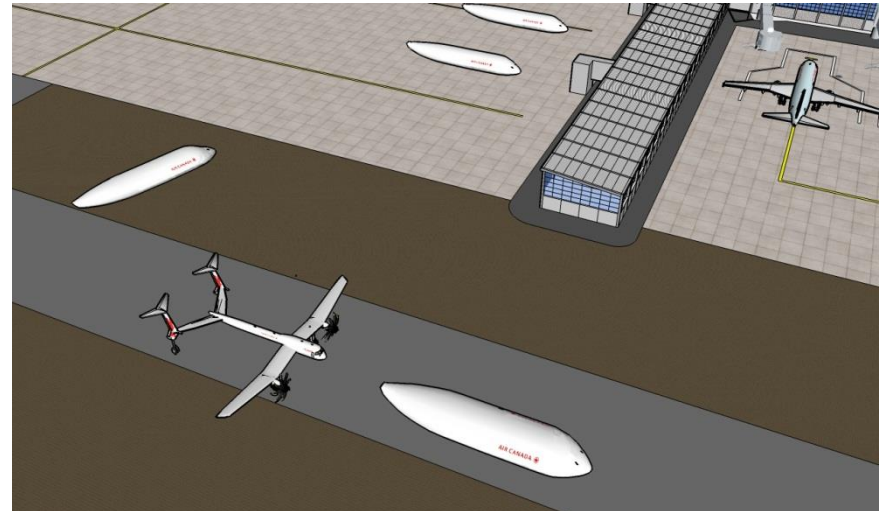

Goal : reduce by 50% cost of flight hour

Bee-Plane orientations for TRL2

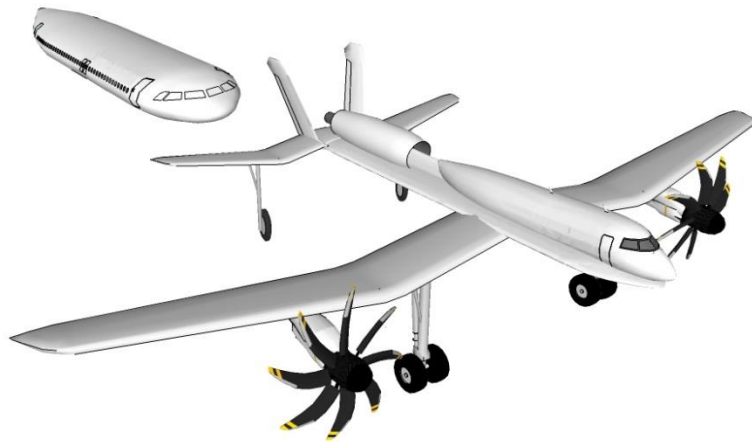

Detachable fuselage
Size of an Airbus A321
200/220 PAX

Overall load 100 T
Engines : 2*TP400 + 2*Silvercrest

Projet 2050 vision

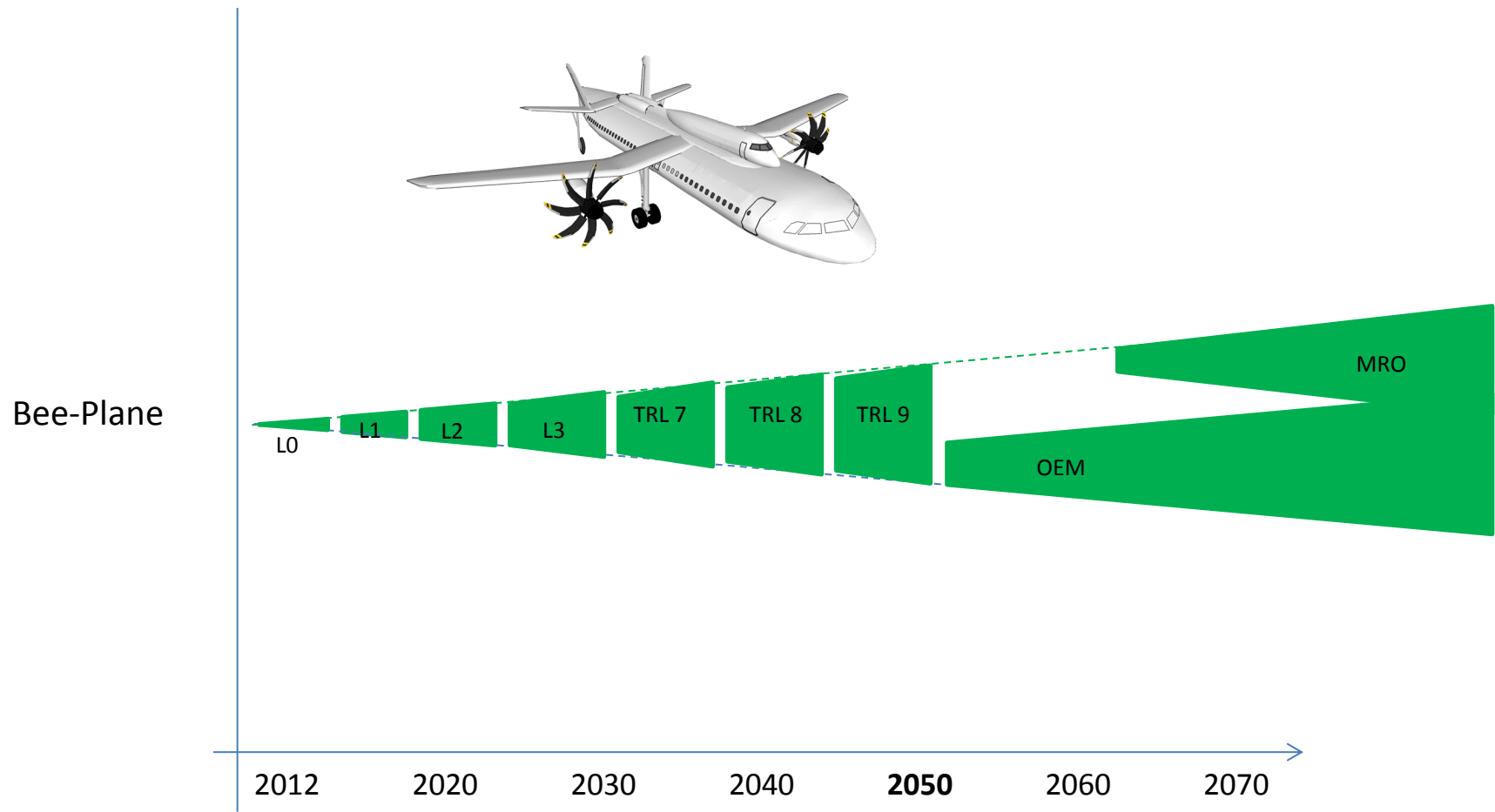

Bee-Plane – Future markets

Nearly 20 000 aircraft to be delivered in 20 years

Airbus



Boeing



Nasa



10% of market represents 160 Md\$

Bee-Plane - State of the art

Fairchild XC-120 (US)
Years 1950s

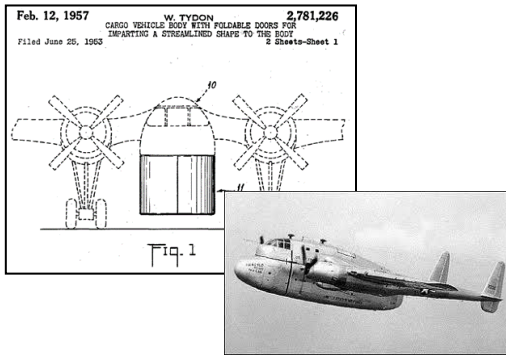

White Knight Two (US)
Load 16t



Flying Wing

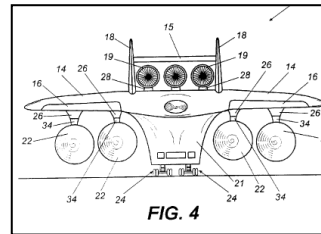

Clip Air (CH)



Configurable Air transport (US)



Skycrane (US)



Mil Mi-10 (RU)

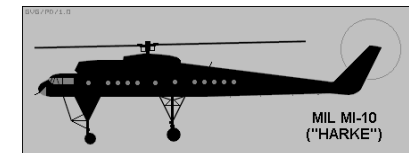

Bee-Plane™ Technology review



Fairchild XC-120
Pack Plane (1950)

&



Electronic
wiring



Noise
reduction



Carbon
body



Turboprop
engine (TP400)

=



Double
body

Vocabulary

- « TRLs » for technical readiness level
- « Levels » for public fundings
 - Level L0 : 1m€ (public funding ~600k€)
 - Level L1 : 5m€ (public funding ~3m€)

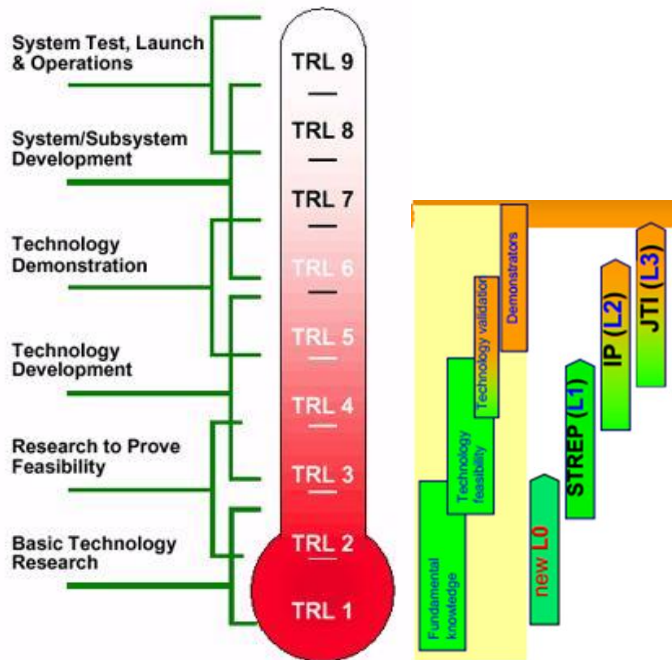

Technology Readiness Level (TRL) - European Space Agency	
TRL	Description
TRL 9.	Actual system "Flight proven" through successful mission operations
TRL 8.	Actual system completed and "Flight qualified" through test and demonstration (ground or space)
TRL 7.	System prototype demonstration in a space environment
TRL 6.	System/subsystem model or prototype demonstration in a relevant environment (ground or space)
TRL 5.	Component and/or breadboard validation in relevant environment
TRL 4.	Component and/or breadboard validation in laboratory environment
TRL 3.	Analytical & experimental critical function and/or characteristic proof-of-concept
TRL 2.	Technology concept and/or application formulated
TRL 1.	Basic principles observed and reported

**Lesser Open Bee
License 1-2**



Bee-Plane – technical description



Bee-Plane

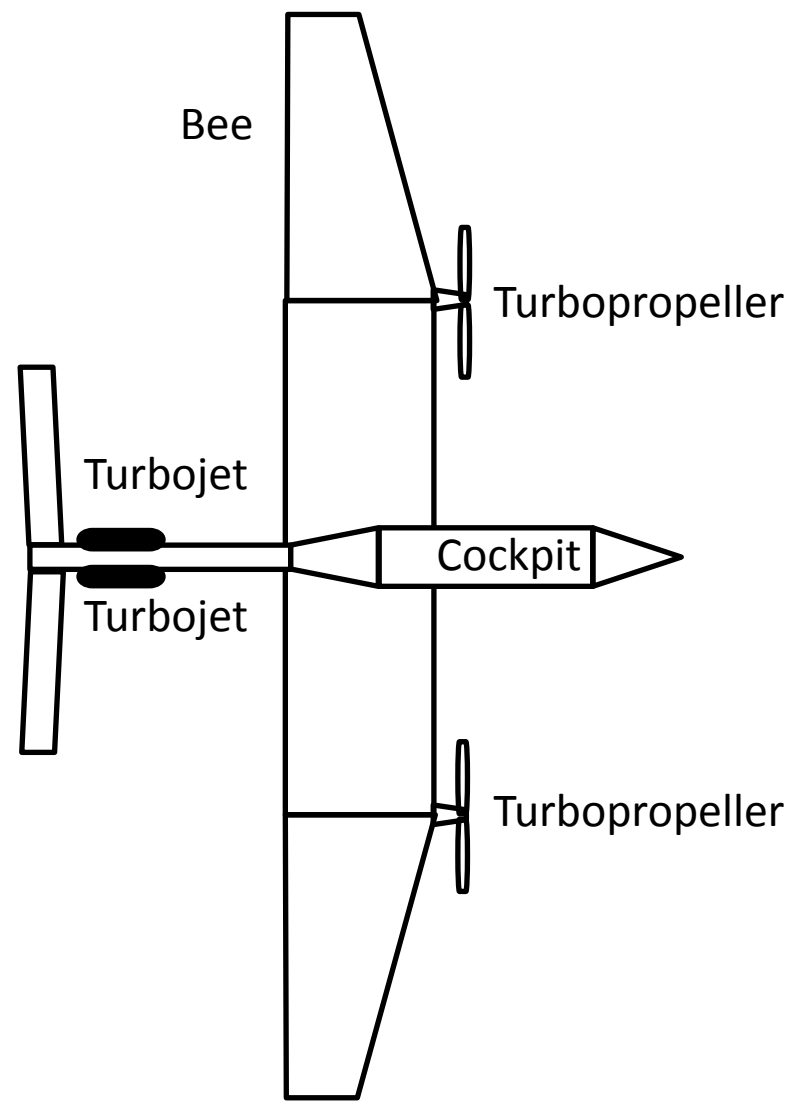
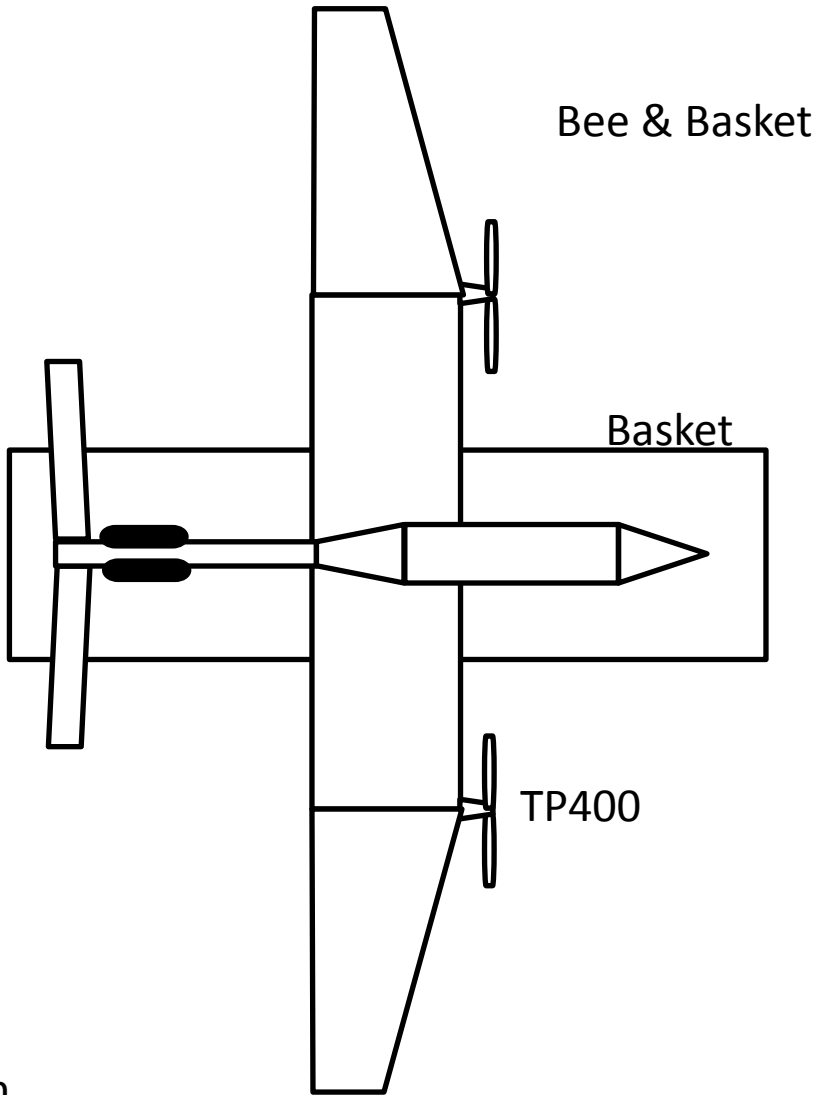

5m



Bee-Plane

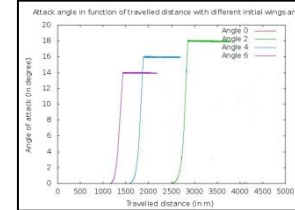
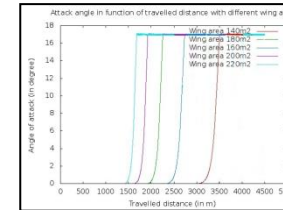
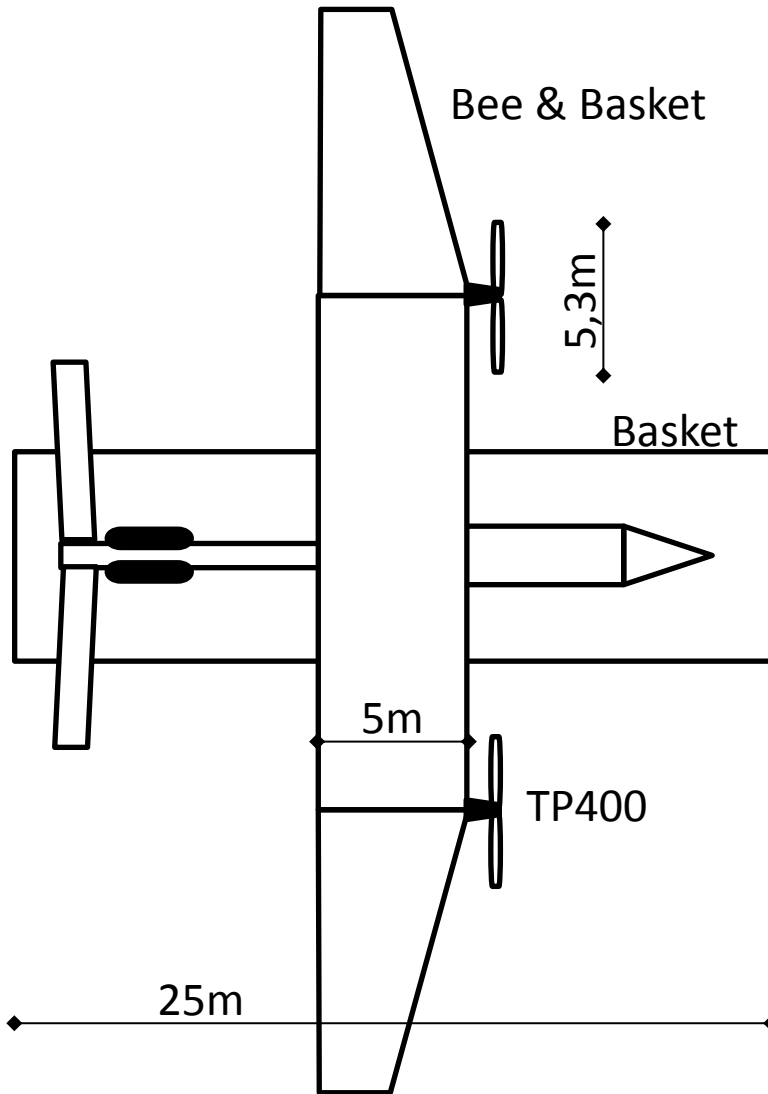

Thrust Analysis - INSA Rouen 2013

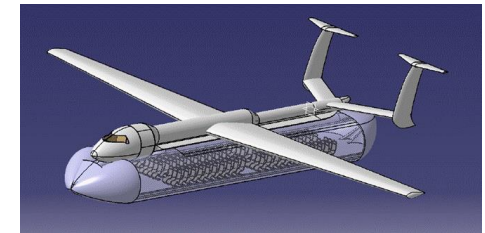

Shape and structure - Estaca 2012

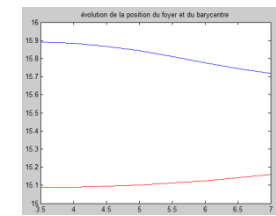

Aero parameters - Centrale Paris 2013



Flight stability

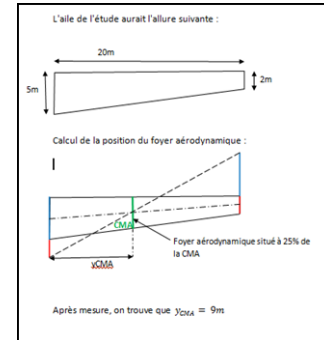
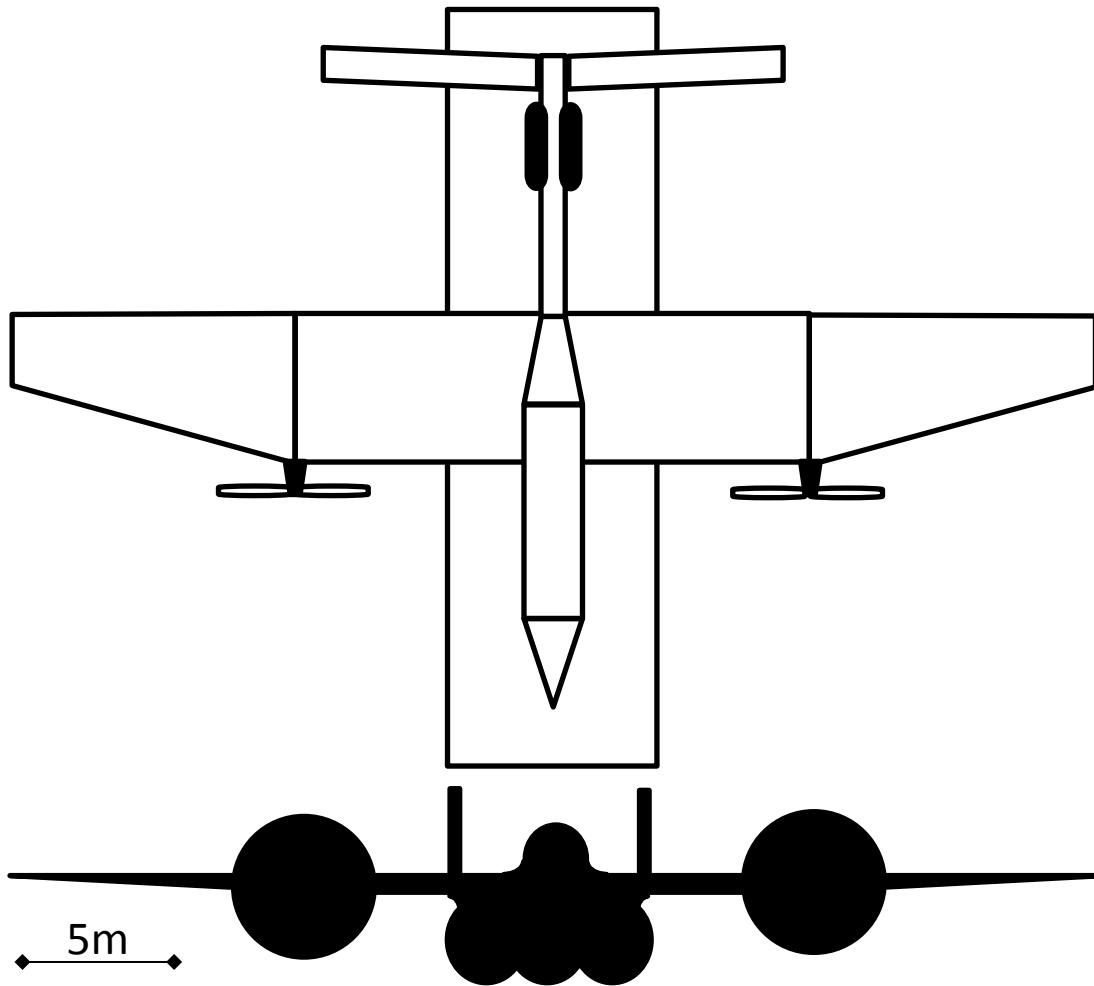

Estaca 2012

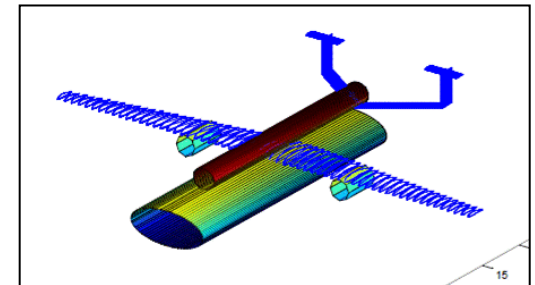

Centrale Paris 2013

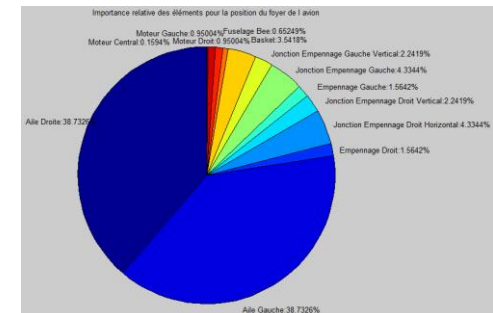

Baskets

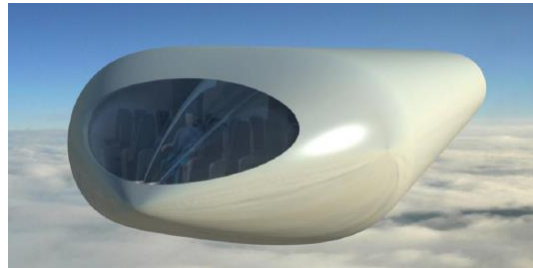
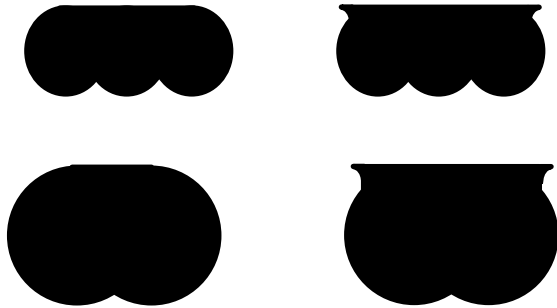

Estaca 2012

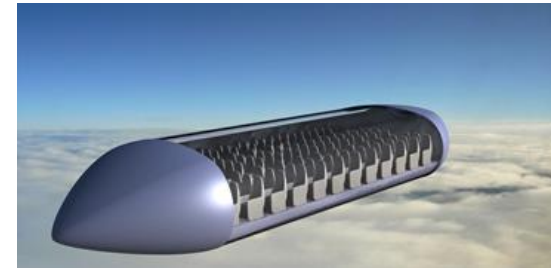

Estaca 2012

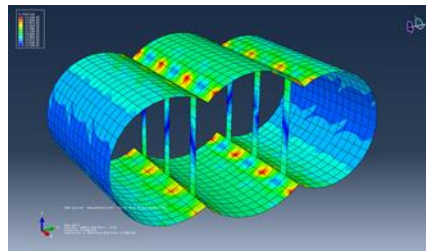

Estaca 2012

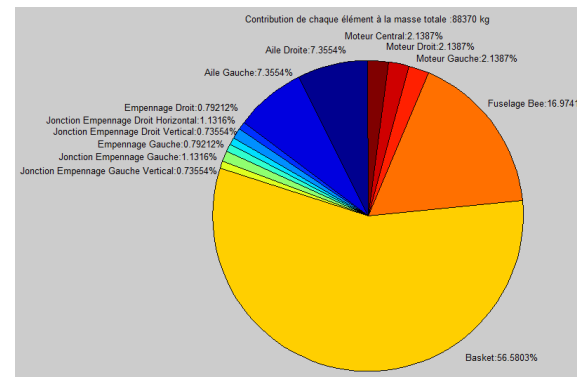

Centrale Paris 2013



Passengers Baskets

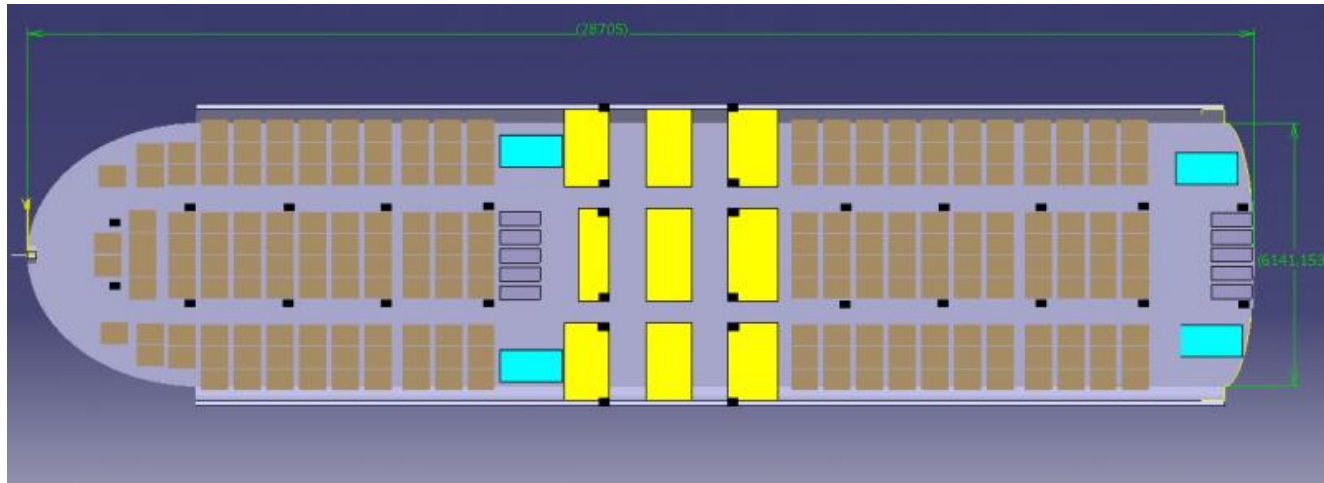
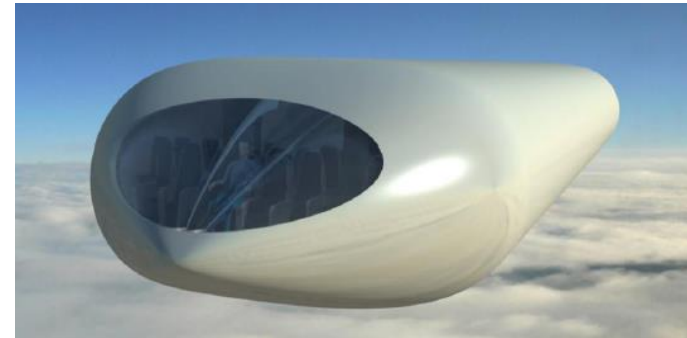
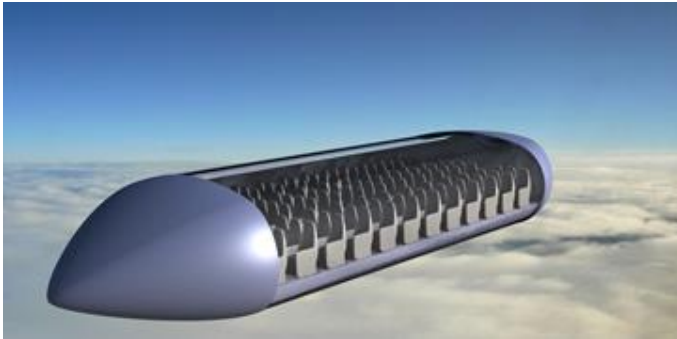

Hospital Basket

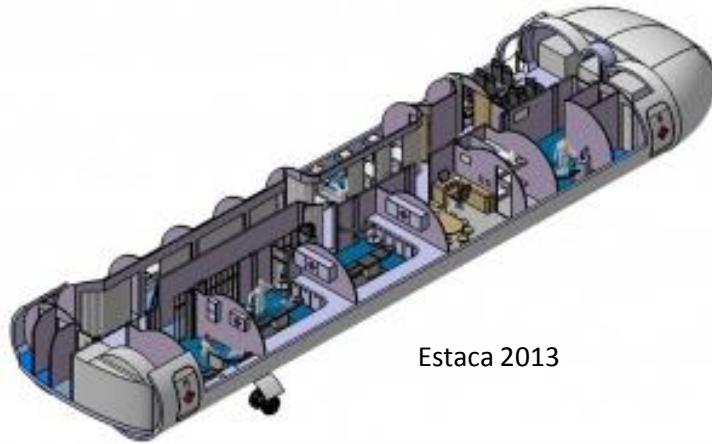

Estaca 2013

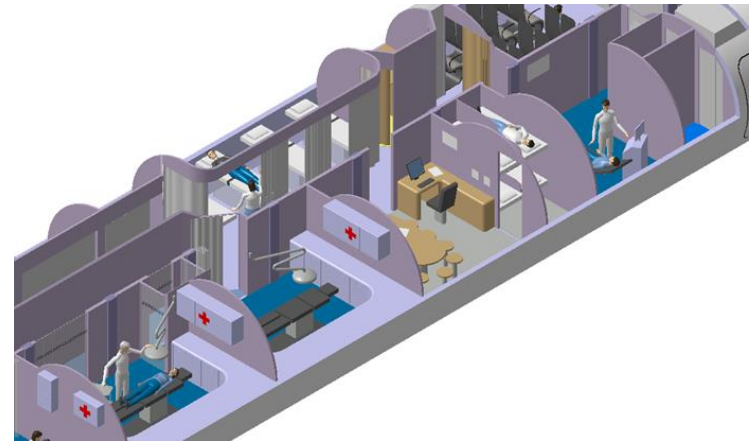

Bee-Plane

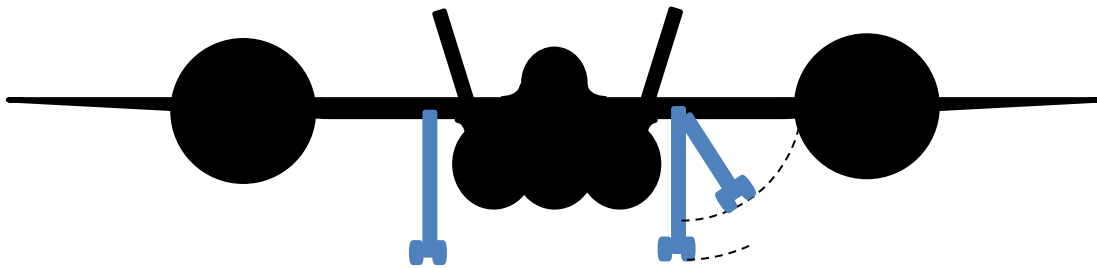
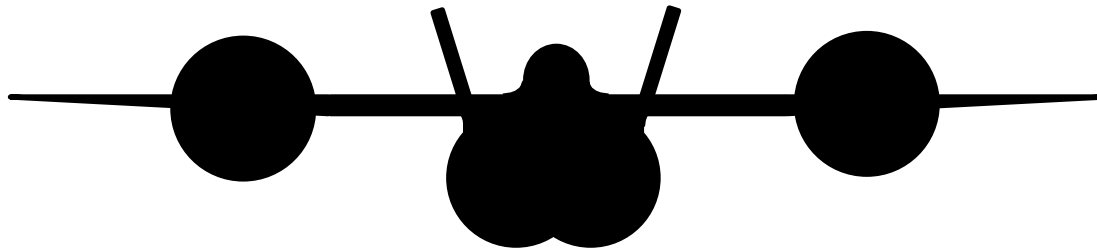
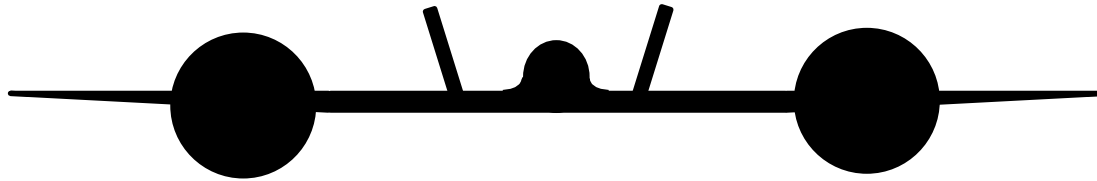

5m



Bee-Plane



Taxiing with basket

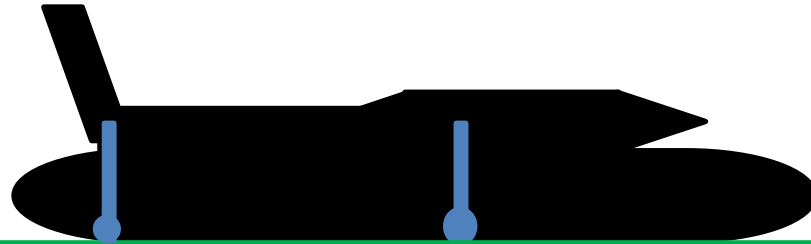

Basket drop



Taxiing without basket

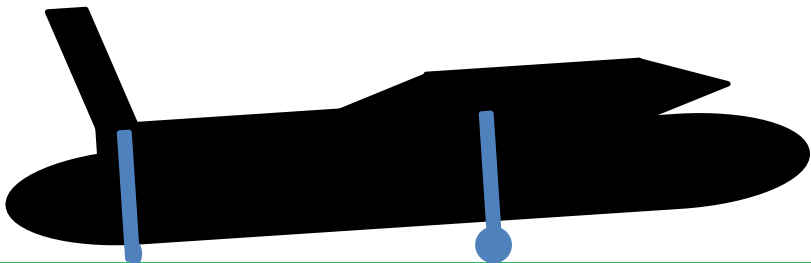

Take-off / Landing
Only front landing gear is
extended : 5 meters long

5m



Landing gear

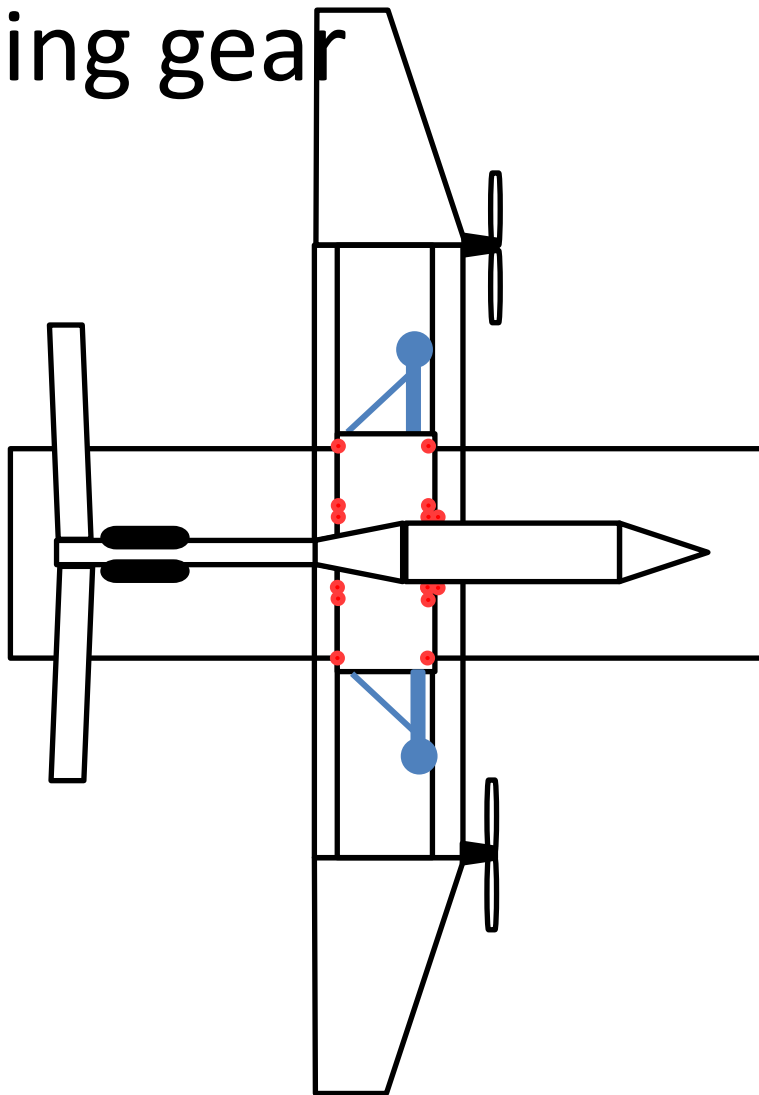

5m

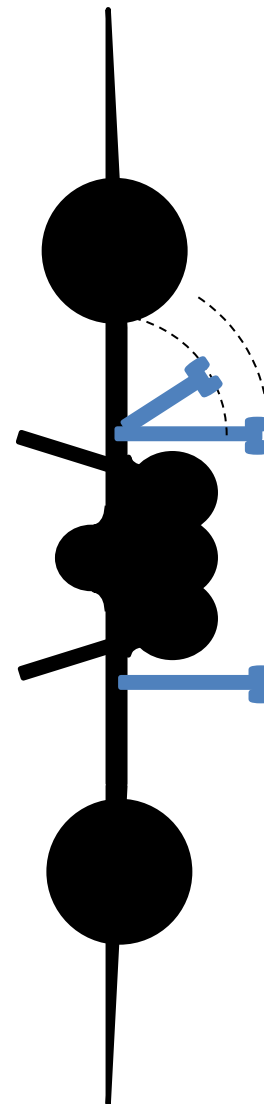

In flight, landing gear is retracted :
3 meters long

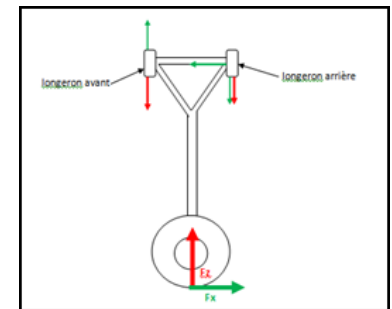

Iso attach System

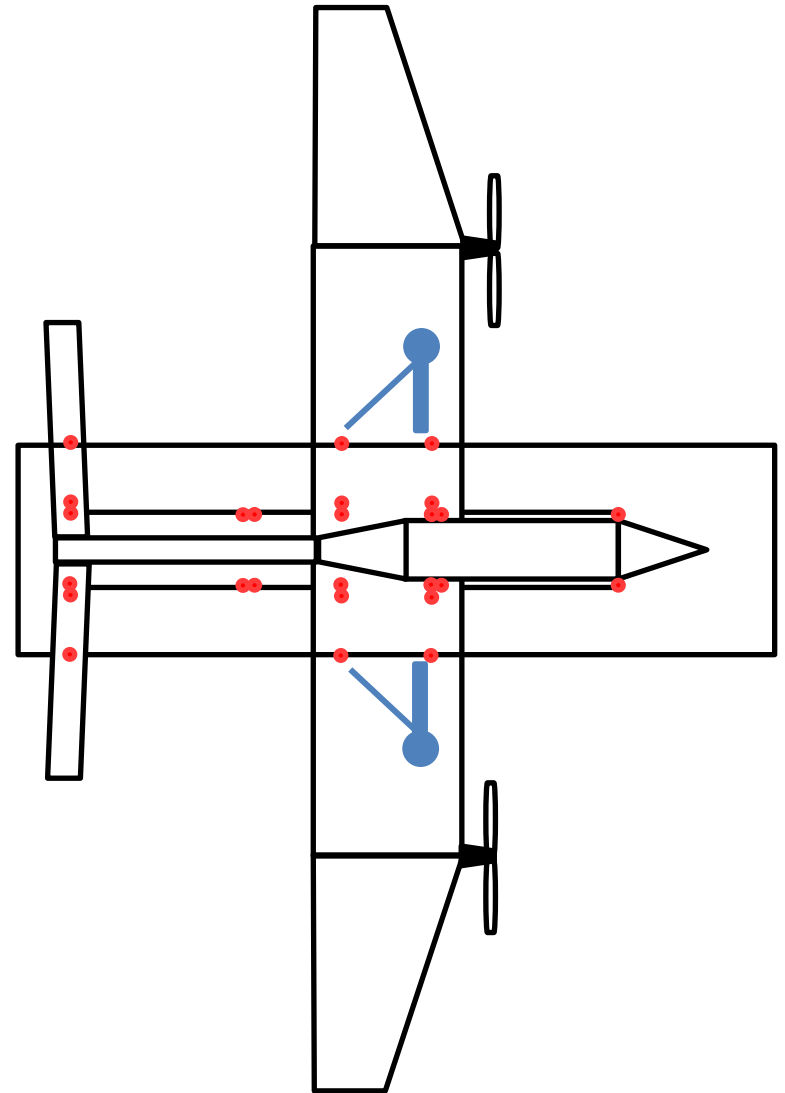
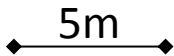
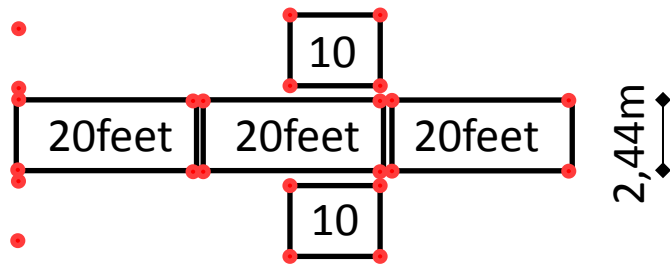
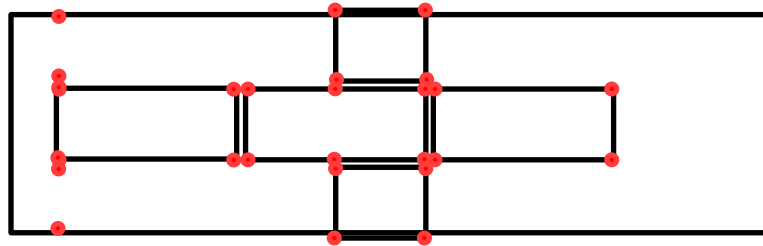

Bee-Plane

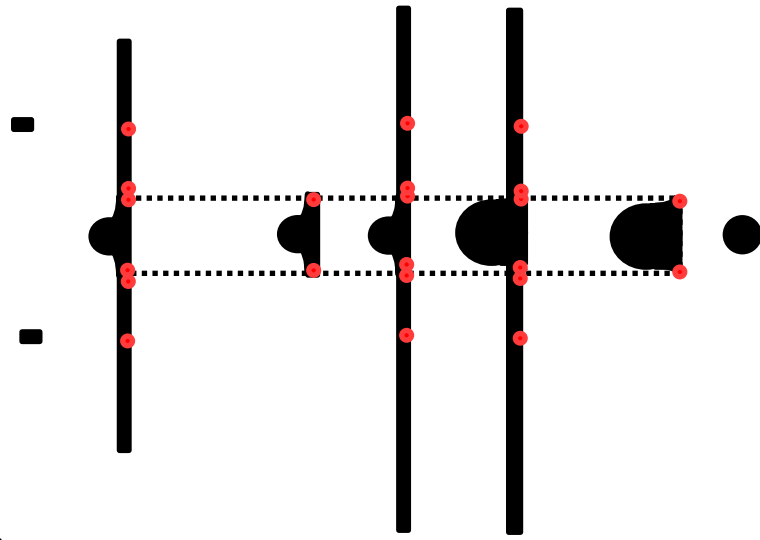
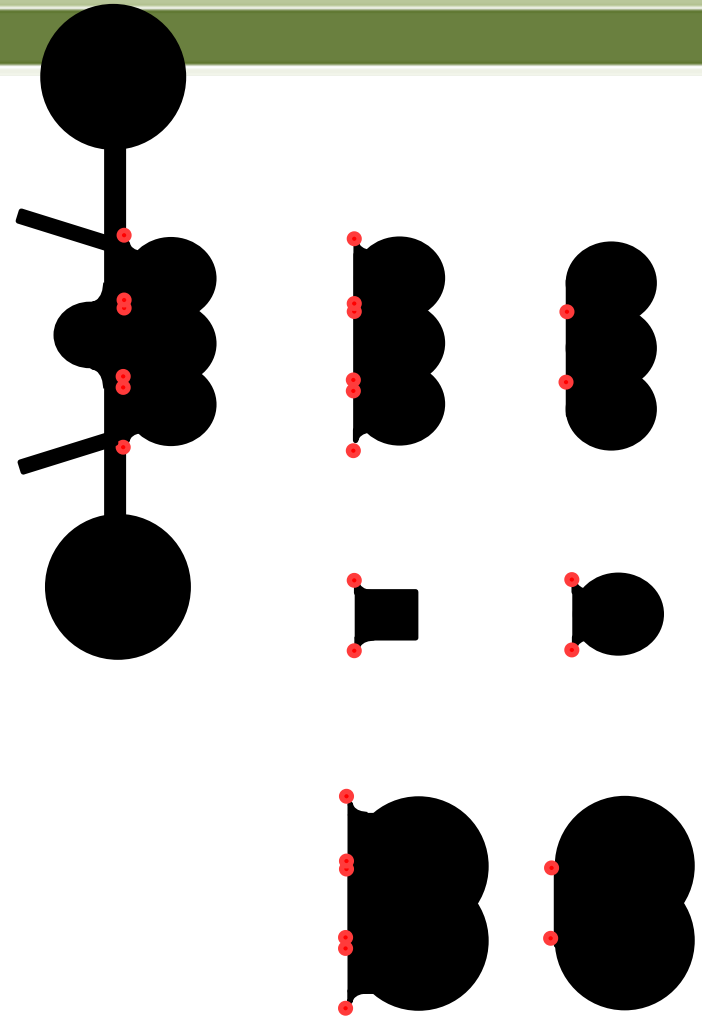
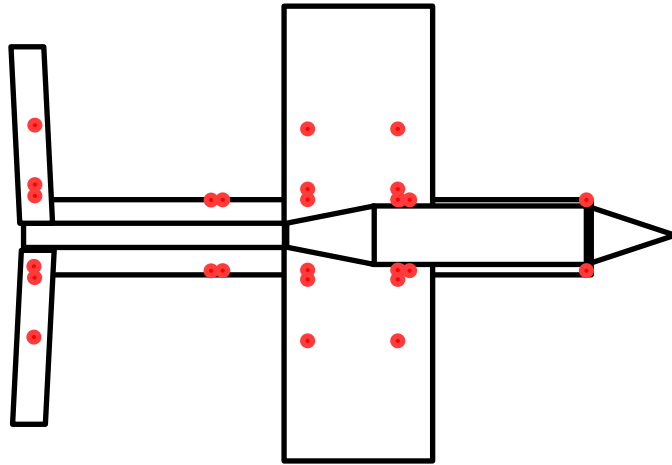

5m



Engines

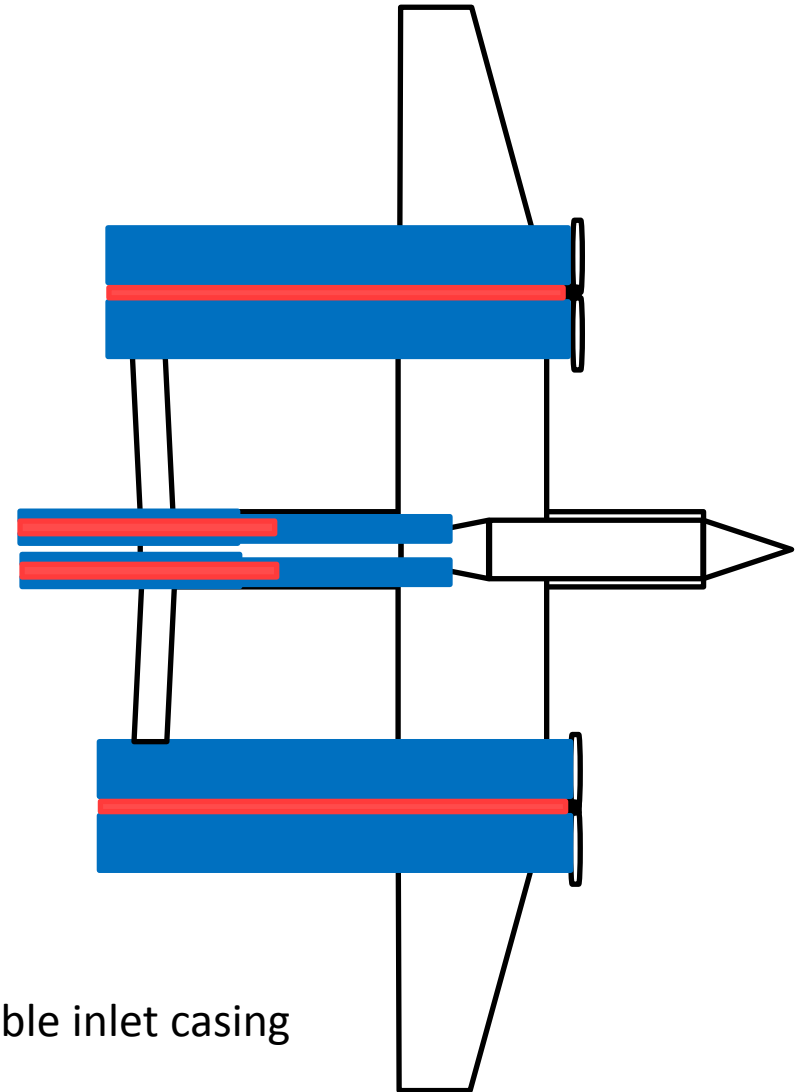
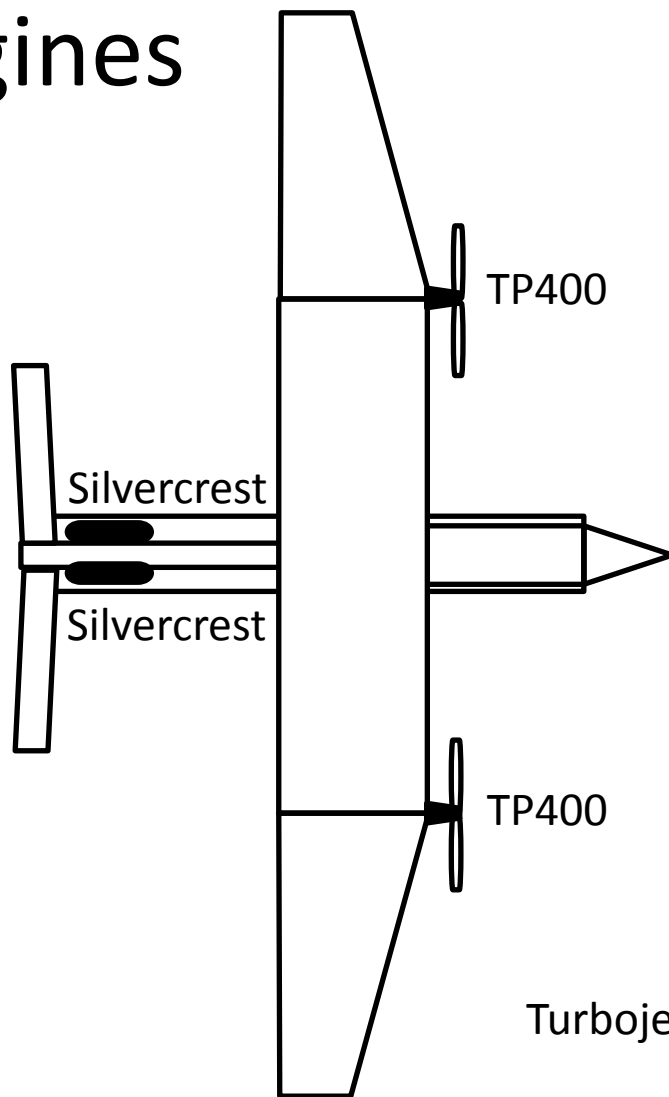

Turbojet with variable inlet casing

5m



Bee-Plane™

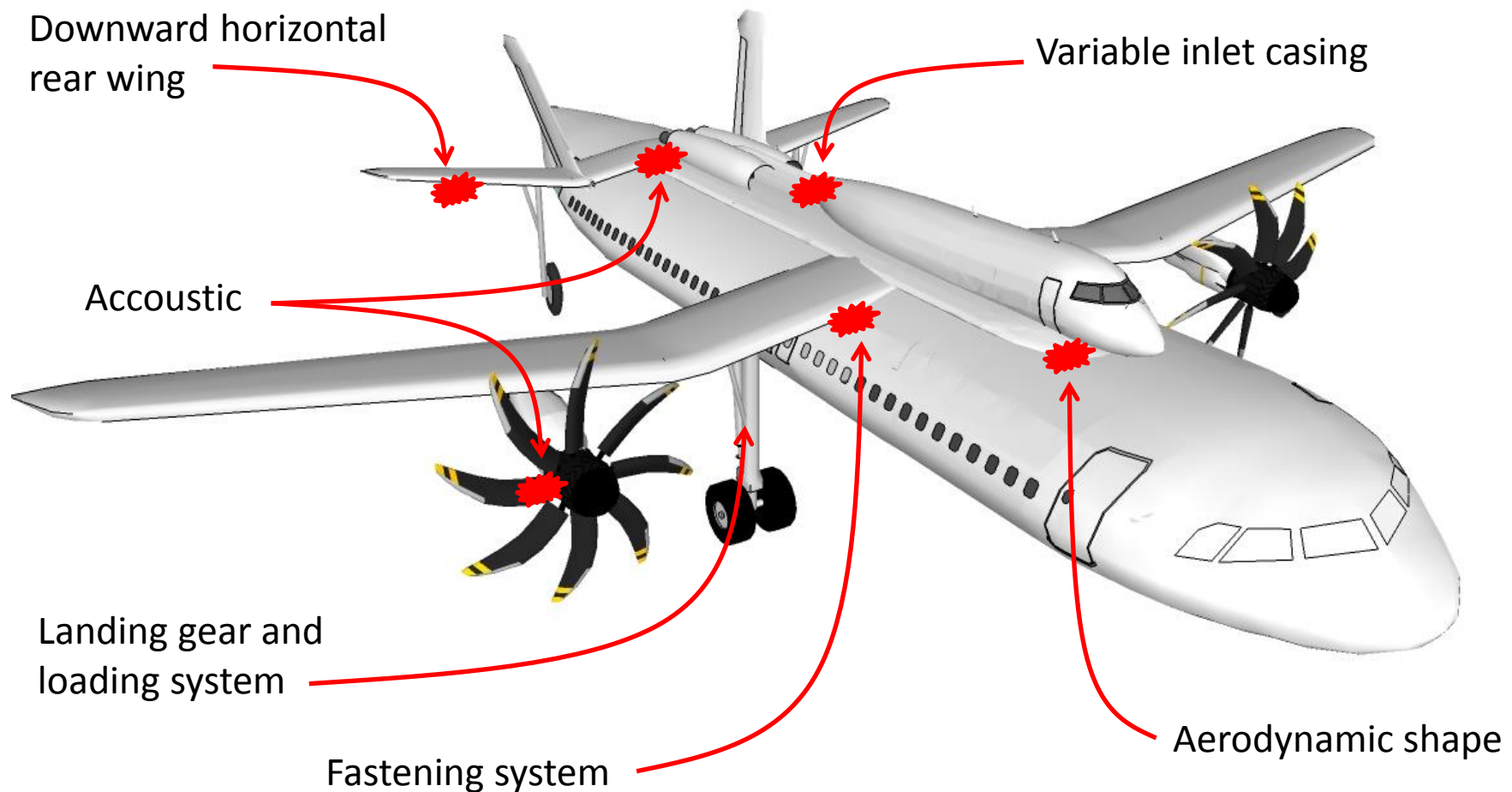

Bee-Plane™

