



CHALLENGE NAE

MiniBee - Tilt Rotor

INTRODUCTION



SOMMAIRE

- Introduction
- Etude du projet
- Tilt Rotor
- Améliorations et points non-traités
- Conclusion

ÉTUDE DU PROJET

Analyse et étude d'avant-projet

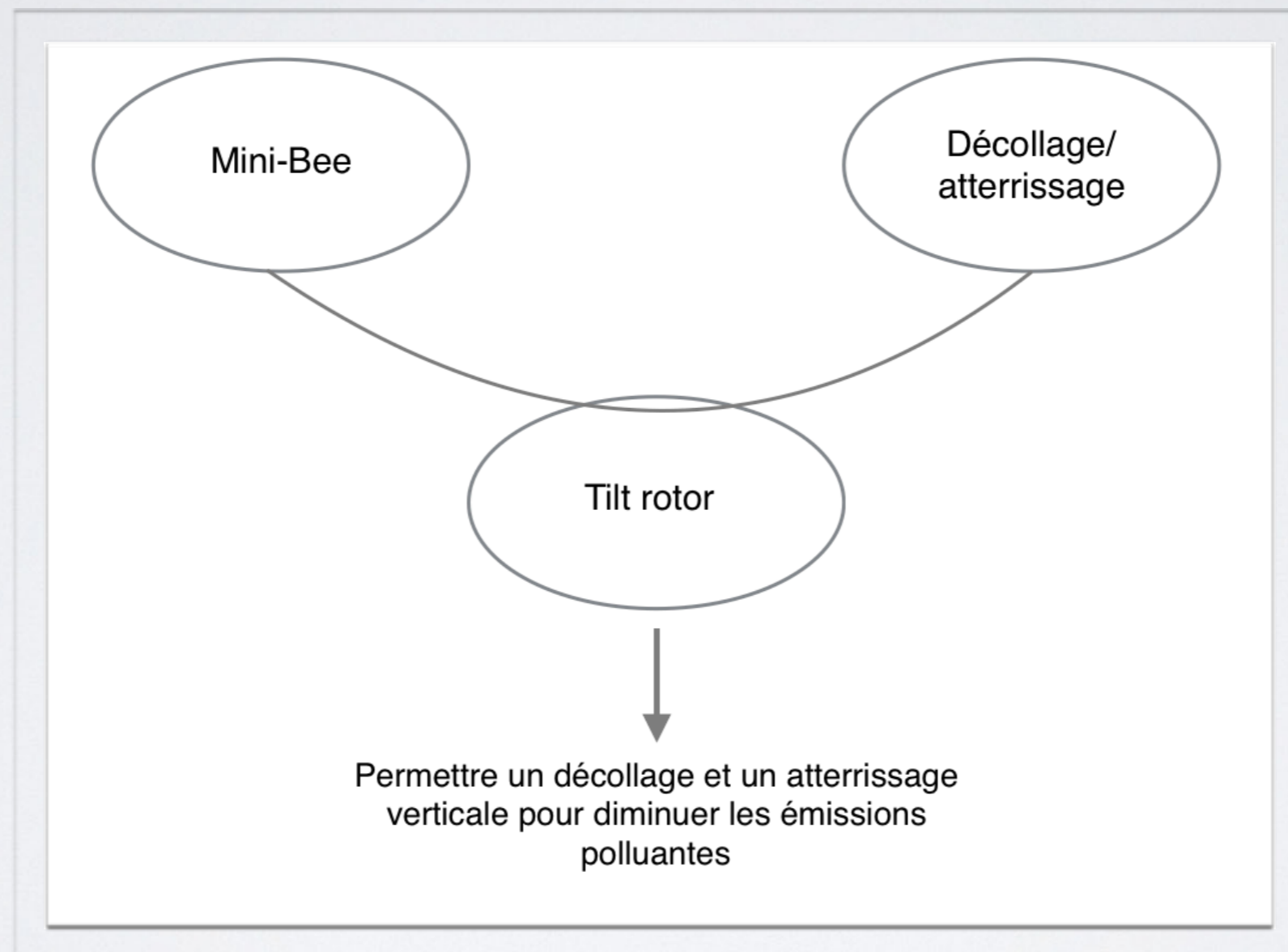

TILT ROTOR

Solution 1

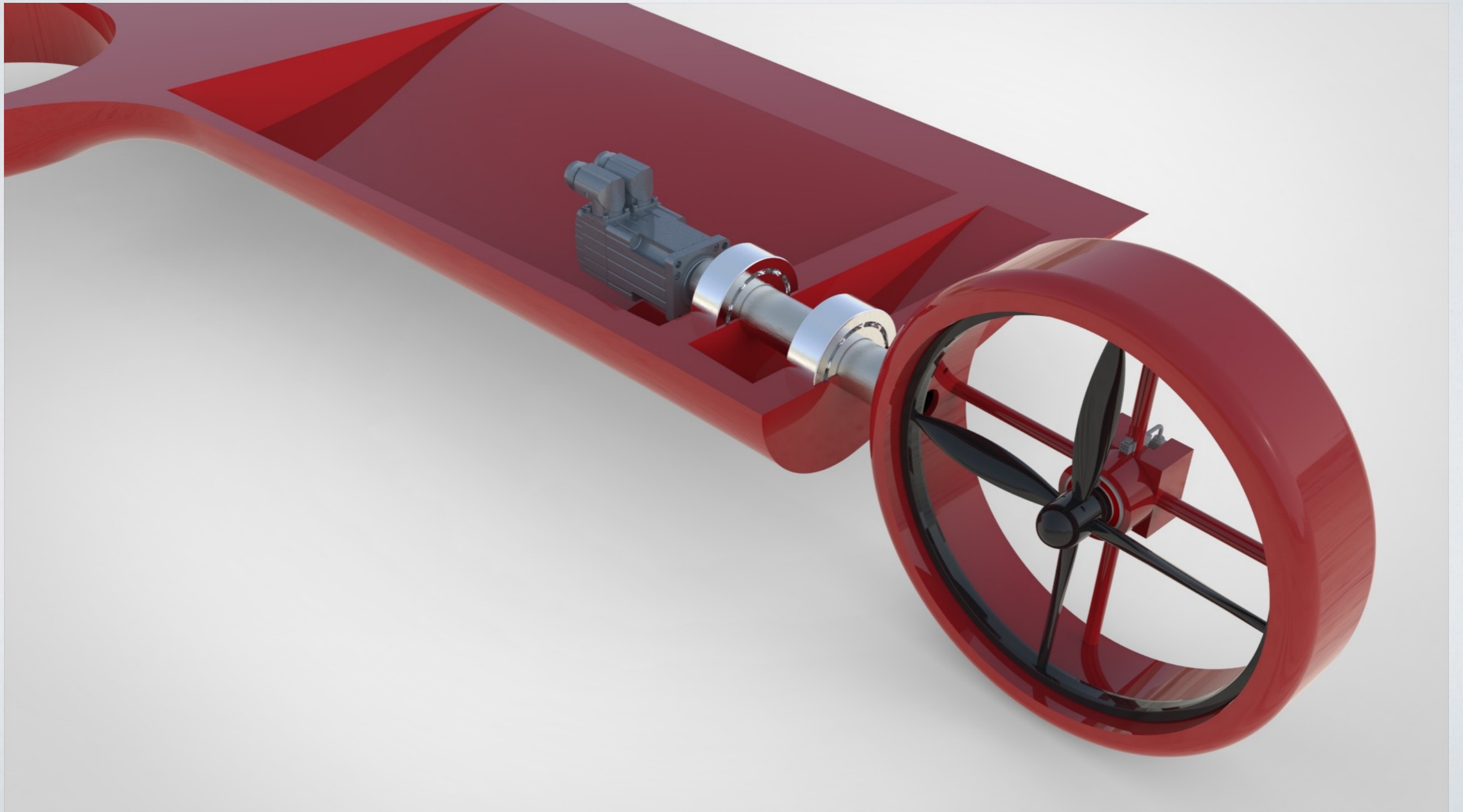

TILT ROTOR

Solution 2

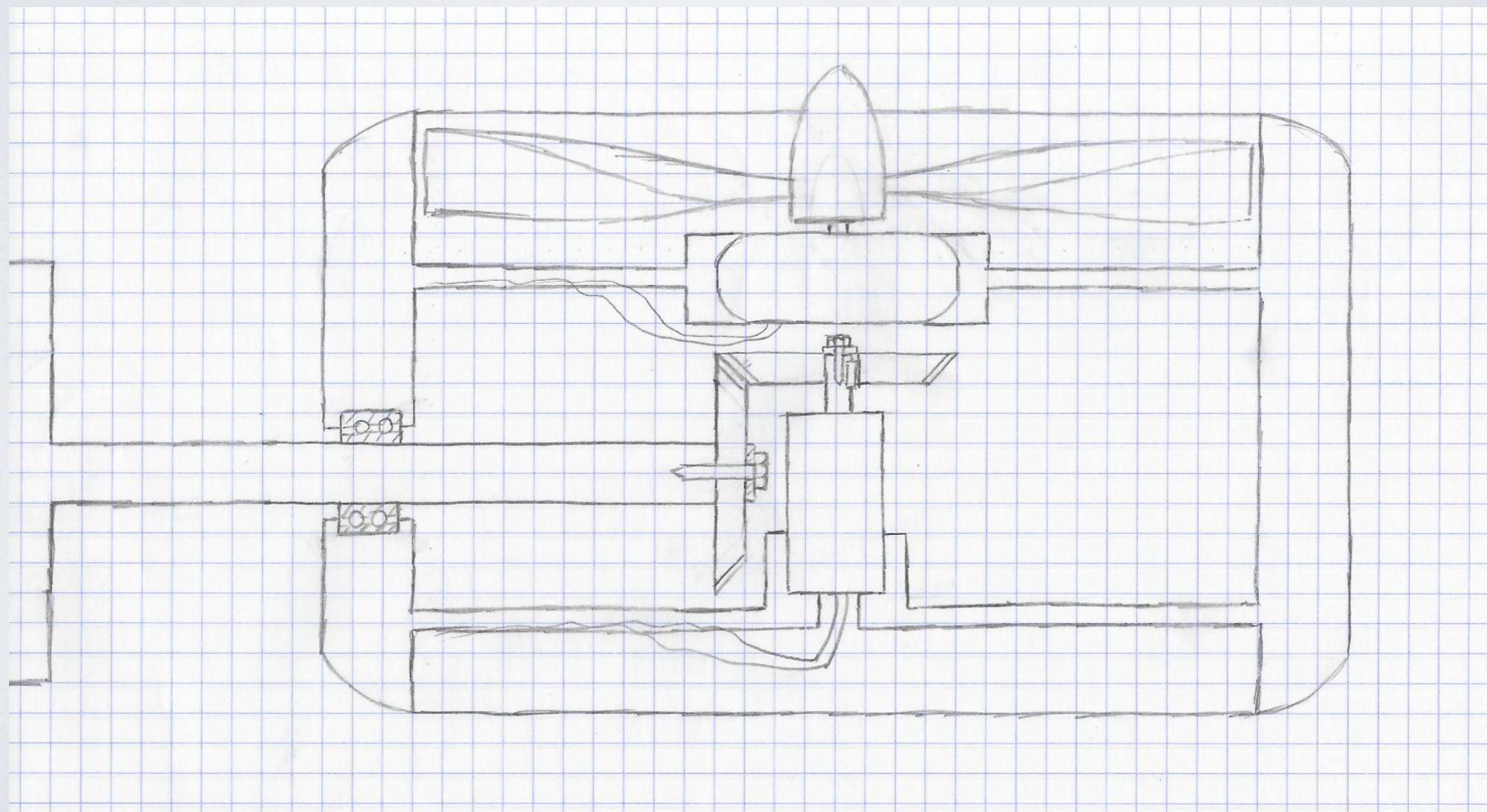

TILT ROTOR

Solution 3

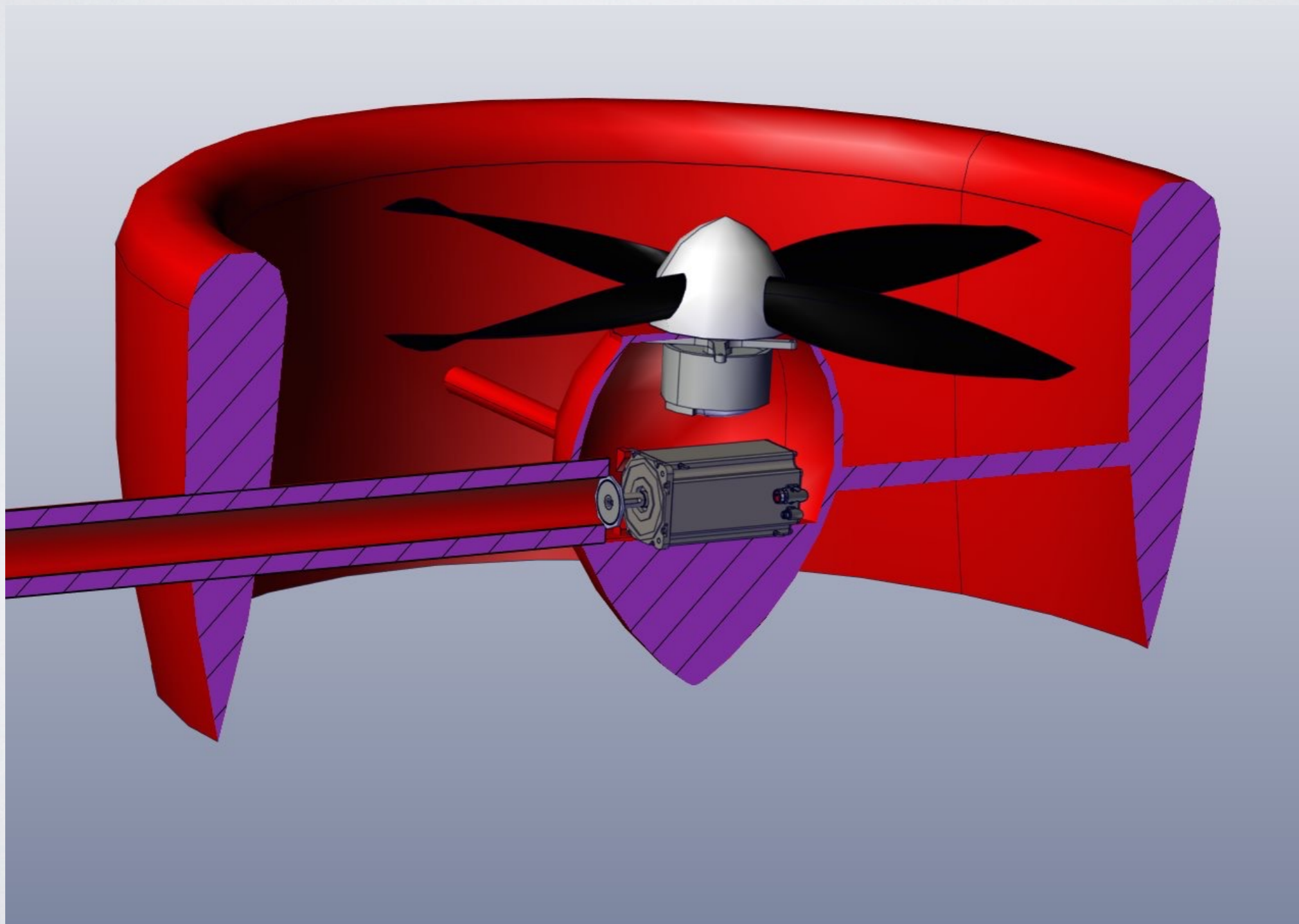

AMÉLIORATIONS ET POINTS NON-TRAITÉS

Commandes

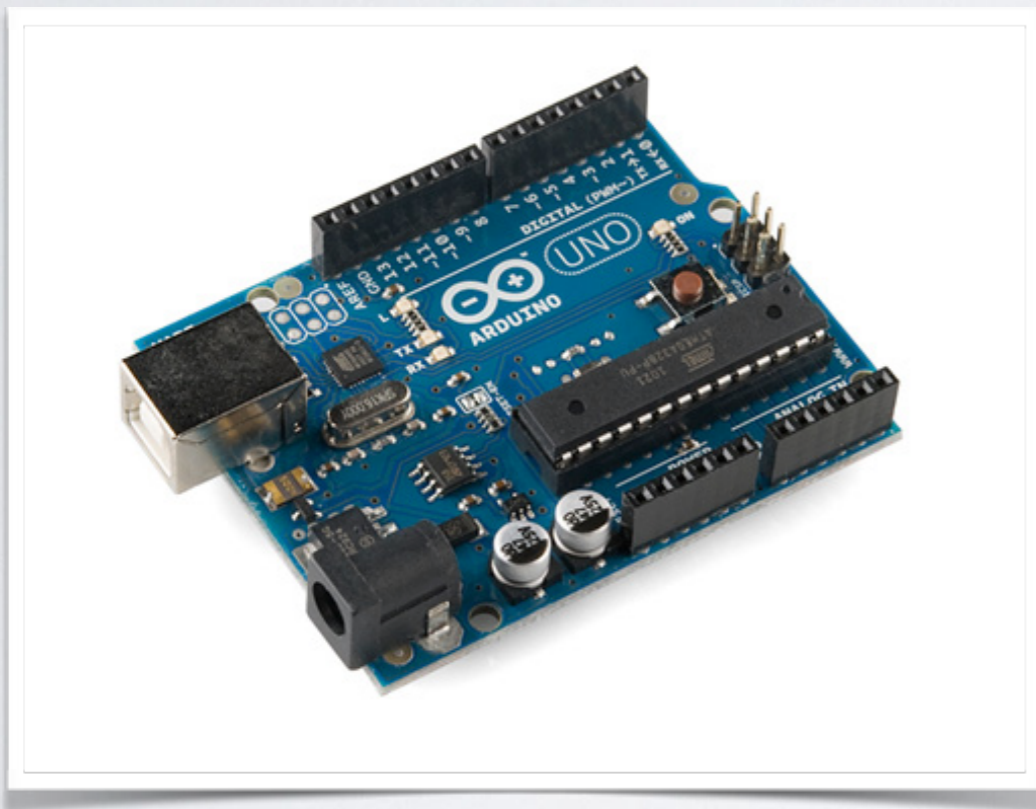

Batteries

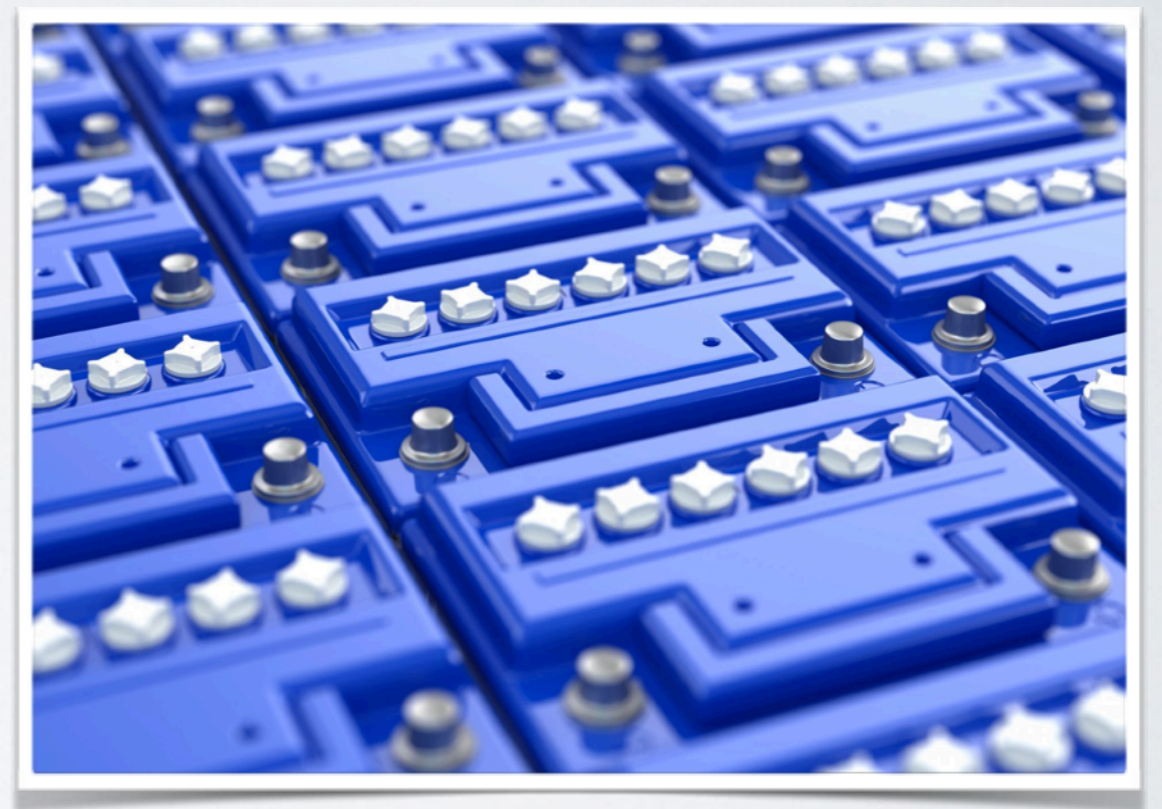

CONCLUSION

